

BOARD TO BOARD CONNECTOR PLUG



1075 SERIES. 1.00 mm. (0.039") Pitch.

General Features

- Available in 09, 11, 13, 15, 17, 19, 21, 23, 25, 31, 41 and 51 circuits
- Mates with plug 1.00 mm pitch 1075 series
- Soldering tabs to fix to PCB

Materials

- Insulator: PA 46 UL 94 V-0
- Contact: Brass
- Operating temperature. -25°C to +85°C
- RoHS compliant

Dimension Information

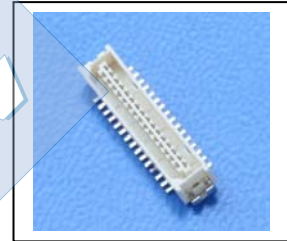
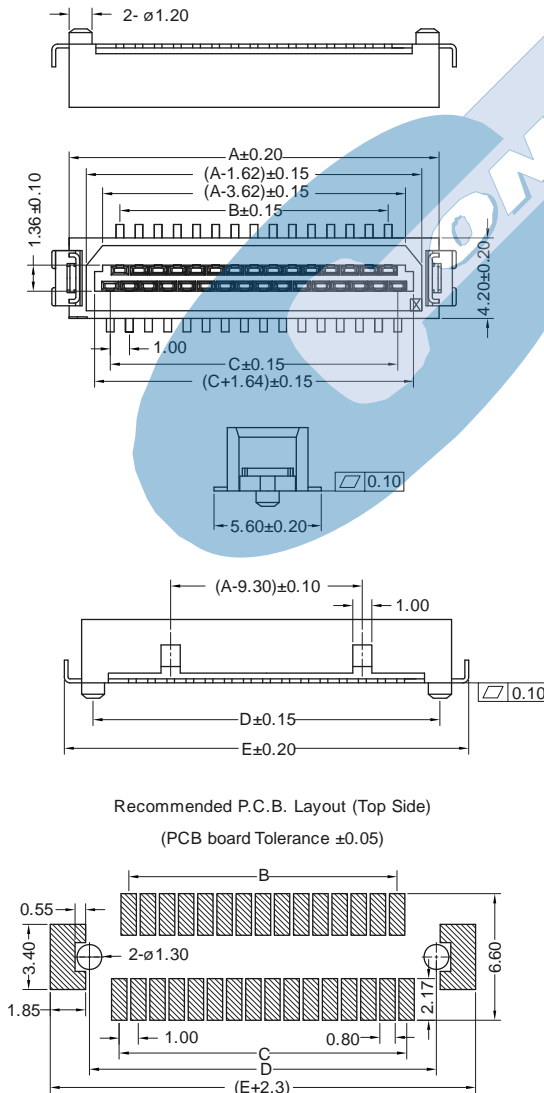

1075 - T- XX- 2 E
 1 2 3 4

1. Connector Serie

2. (T) Contacts Plating

- T = 2. Tin plated
- T = 3. Gold flash over nickel
Recommended Finish
- T = 5. 15µ" gold over nickel
- T = 6. 30µ" gold over nickel

3. (XX) Number of circuits

- Available in 09, 11, 13, 15, 17, 19, 21, 23, 25, 31, 41 and 51 circuits

4. (E) Packing Options

- E = 1. Pad + Tubel
- E = 2. Pad + Reel

Circuits	Dimensions				
	A	B	C	D	E
09	8.3	3	4	7.1	10.1
11	9.3	4	5	8.1	11.1
13	10.3	5	6	9.1	12.1
15	11.3	6	7	10.1	13.1
17	12.3	7	8	11.1	14.1
19	13.3	8	9	12.1	15.1
21	14.3	9	10	13.1	16.1
23	15.3	10	11	14.1	17.1
25	16.3	11	12	15.1	18.1
31	19.3	14	15	18.1	21.1
41	24.3	19	20	23.1	26.1
51	29.3	24	25	28.1	31.1