

BOARD TO BOARD TOP ENTRY CONNECTOR



1507 SERIES. 5.08 mm (0.200") pitch.

General Features

- Available in 2 through 20 circuits
- Mates with 5.08 mm pin header 1.14 mm square/round pin 5086, 5087, 5088, 5084, 5082, 5083, 5071, 5072 and 5075 series
- Flex contact PCB female terminal

Materials

- Insulator: Nylon 66 UL 94 V-2
- Terminal: Tin plated brass
- Operating temperature: -40°C to +105°C
- RoHS compliant

Dimension Information

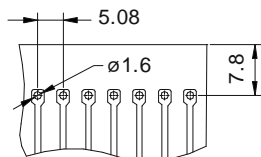
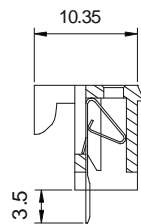
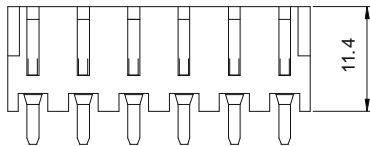
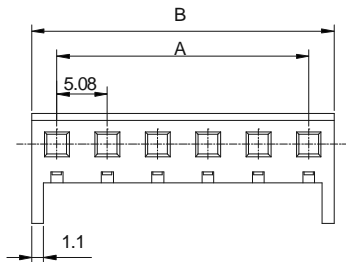

RECOMMENDED PCB LAYOUT
(PCB Thickness = 1.0~1.6 mm.)

Electrical Features

- Voltage rating: < 250V
- Current rating: < 5 A
- Contact resistance: < 20 mΩ
- Dielectric withstanding voltage: 1500 V AC/minute
- Insulation resistance: >1000 MΩ

Mechanical Features

- Contact retention force to insulator: > 1.00 Kgf
- Insertion force to header: < 1.00 Kgf/pin
- Withdrawal force from header: < 0.15 Kgf/pin
- Durability: 25 cycles

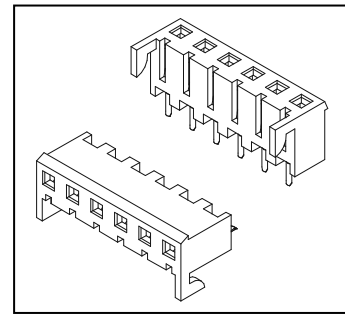

Ordering Information:

1507 - 2- XX- 1
1 2 3

1. Connector Series

3. (XX) Number of circuits

- Available in 2 through 20 circuits

Dimensions: (In mm.)

A = 5.08 x (XX*-1)

B = 5.08 x (XX)

* XX (Number of circuits)