

CRIMP TERMINAL



2033 SERIES. 2.00 mm. (0.039") Pitch housing

General Features

- Accommodates wire range AWG 24 through 30
- Use in housing 2.00 mm pitch 2010 series
- Dual beam contact with tin plated locking lance
- Maximum insulation diameter 1.24 mm (0.049")

Materials

- Contact: Phosphor bronze
- Operating temperature -40°C to +85°C

Dimensional Information

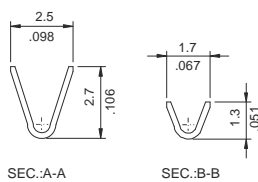
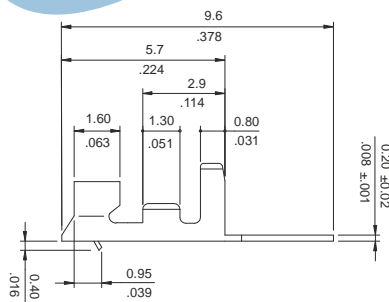
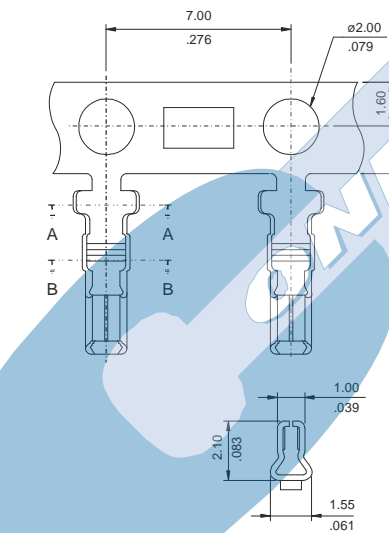

Electrical Features

- Current rating: < 2 A
- Contact resistance: < 20 mΩ

Mechanical Features

- Durability: 25 cycles
- Wire pull-out force:
 - 3.00 Kg 24 AWG
 - 2.00 Kg 26 AWG
 - 1.30 Kg 28 AWG
 - 0.80 Kg 28 AWG



2033 - 2- 00- E
1 2

1. Terminal Serie

2. (E) Packing Options

- E = 0. Chain
- E = 1. Loose Piece