

CRIMP TERMINAL



2084 SERIES. 2.00 mm. (0.079") Pitch

General Features

- Accommodates wire range AWG 24 through 30
- Use in housing 2.00 mm pitch 2080 series
- Tin plated dual beam contact with locking lance
- Maximum insulation diameter 1.45 mm (0.057")

Materials

- Contact: Phosphor bronze
- Operating temperature -40°C to +85°C

Dimensional Information

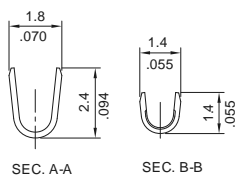
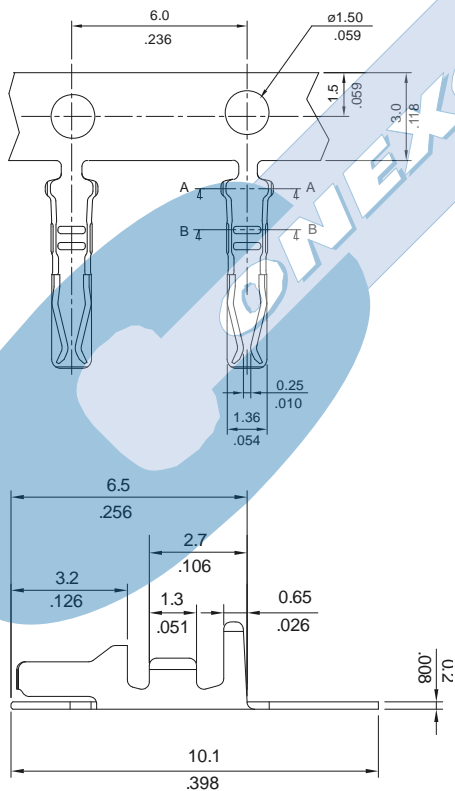

Electrical Features

- Current rating: < 2 A
- Contact resistance: < 20 mΩ

Mechanical Features

- Durability: 25 cycles
- Wire pull-out force:
 - 3.00 Kgf 24 AWG
 - 2.00 Kgf 26 AWG
 - 1.00 Kgf 28 AWG
 - 0.80 Kgf 30 AWG



2084 - 2- 00- E
1 2

1. Terminal Serie

2. (E) Packing Options

- E = 0. Chain
- E = 1. Loose Piece