

CRIMP TERMINAL



2453 SERIES. 2.50 mm. (0.098") Pitch housing

General Features

- Accommodates wire range AWG 22 through 28
- Use in housing 2.50 mm pitch 2420 series
- Box contact with tin plated locking lance
- Maximum insulation diameter 1.90 mm (0.075")

Materials

- Contact: Tin pre plated Brass
- Operating temperature -40°C to +85°C

Dimensional Information

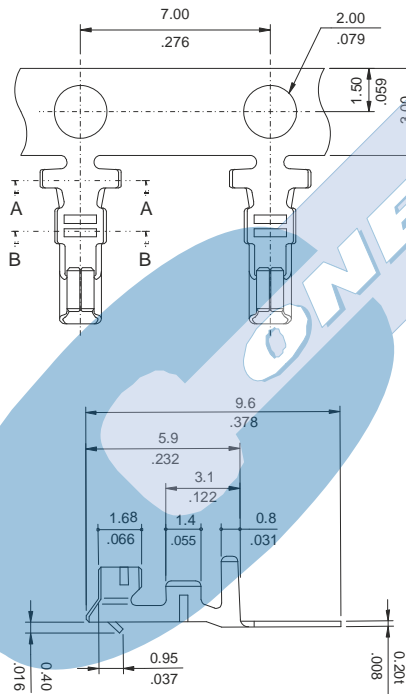

Electrical Features

- Current rating: < 3 A
- Contact resistance: < 20 mΩ

Mechanical Features

- Durability: 25 cycles
- Wire pull-out force: 5.00 Kgf 22 AWG
3.00 Kgf 24 AWG
2.00 Kgf 26 AWG
1.00 Kgf 28 AWG



2453 - 2- 00- E
1 2

1. Terminal Serie

2. (E) Packing Options

- E = 0. Chain
- E = 1. Loose Piece