

CRIMP TERMINAL



2573 SERIES. 2.50 mm. (0.098") Pitch housing

General Features

- Accommodates wire range AWG 22 through 28
- Use in housing 2.50 mm pitch 2574 series
- Maximum insulation diameter 1.70 mm (0.075")

Electrical Features

- Current rating: < 3 A
- Contact resistance: < 20 mΩ

Materials

- Contact: Tin pre plated Brass
- Operating temperature -40°C to +85°C

Mechanical Features

- Durability: 25 cycles
- Wire pull-out force:
 - 4.00 Kgf 22 AWG
 - 3.00 Kgf 24 AWG
 - 2.00 Kgf 26 AWG
 - 1.00 Kgf 28 AWG

Dimensional Information

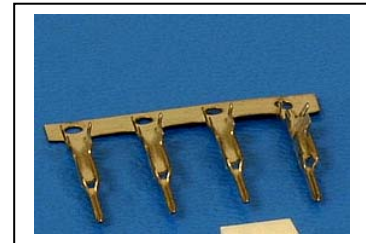
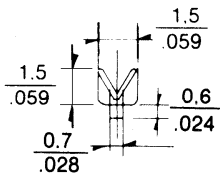
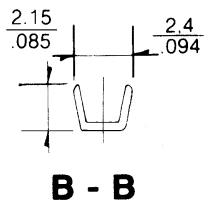
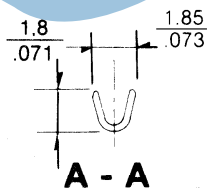
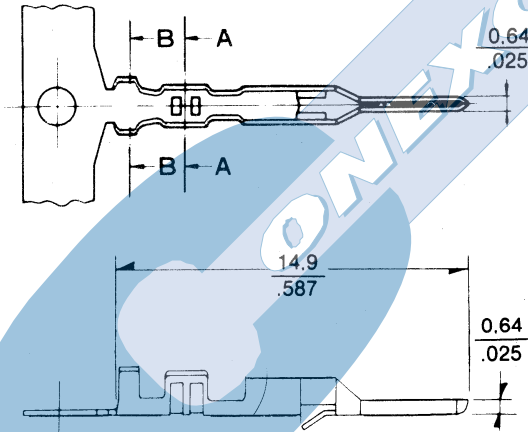

2573 - 2- 00- E
1 2

1. Terminal Serie

2. (E) Packing Options

- E = 0. Chain
- E = 1. Loose Piece