

BOARD TO BOARD TOP ENTRY CONNECTOR



2621 SERIES. 2.50 mm. (0.098") Pitch.

General Features

- Available in 2 through 15 circuits
- Mates with 2.50 mm. pin header 2521 and 2522 series
- Box contact Pcb female terminal
- Fully shrouded with friction lock

Materials

- Insulator: Nylon 6/6 UL 94 V-0
- Terminal: Tin plated brass
- Operating temperature. -25°C to +85°C
- RoHS compliant

Dimensional Information

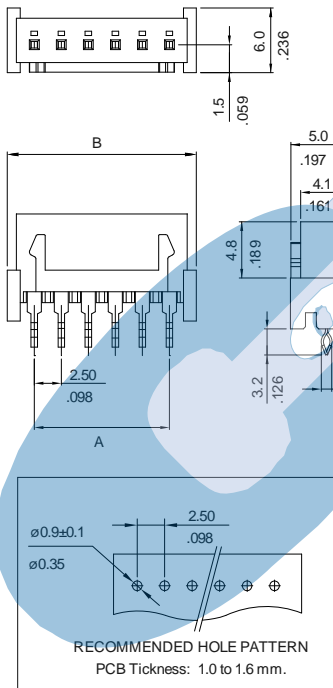

Electrical Features

- Voltage Rating: < 250 V
- Current Rating: < 3 A
- Contact resistance: < 20 mΩ
- Dielectric withstanding voltage: 1000 V AC/minute
- Insulation resistance: >1000 MΩ

Mechanical Features

- Pin retention force to insulator: > 1.00 Kgf
- Durability: 25 cycles

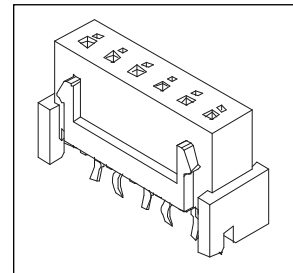

2621 - 2- XX- 1
1 2 3

1. Connector Serie

3. (XX) Number of circuits

- Available in 2 through 15 circuits

Dimensions: (in mm.)

A = 2.50 x (XX*-1)

B = 2.50 x (XX*)+2.50

*XX (Number of circuits)

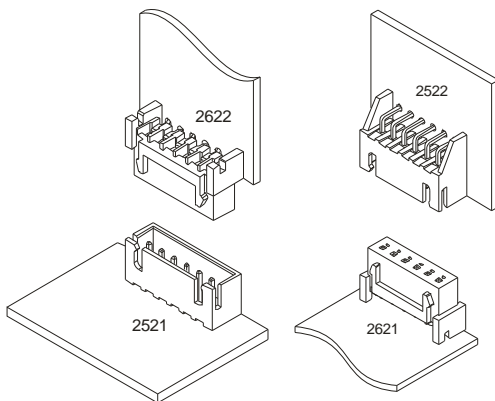

Assembly options and dimensions:

