

CRIMP TERMINAL



2870 SERIES. 2.54 mm. (0.100 ") Pitch housing.

General Features

- Accommodates wire range AWG 22 through 28
- Use in housing 2.54 mm pitch 2866, 2642 and 2695 series
- Dual Beam box contact with locking lance
- Maximum insulation diameter 1.70 mm (0.067")

Materials

- Contact: Phosphor bronze tin pre-plated
- Operating temperature -40°C to +85°C

Electrical Features

- Current rating: < 3 A
- Contact resistance: < 20 mΩ

Mechanical Features

- Durability: 25 cycles
- Wire pull-out force:
 - 4.00 Kgf 22 AWG
 - 3.00 Kgf 24 AWG
 - 2.00 Kgf 26 AWG
 - 1.00 Kgf 28 AWG

Dimensional Information

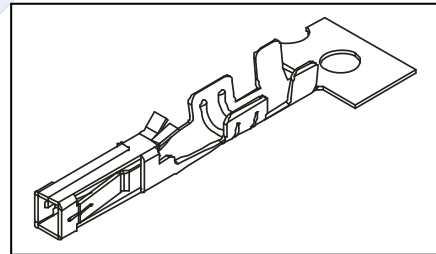
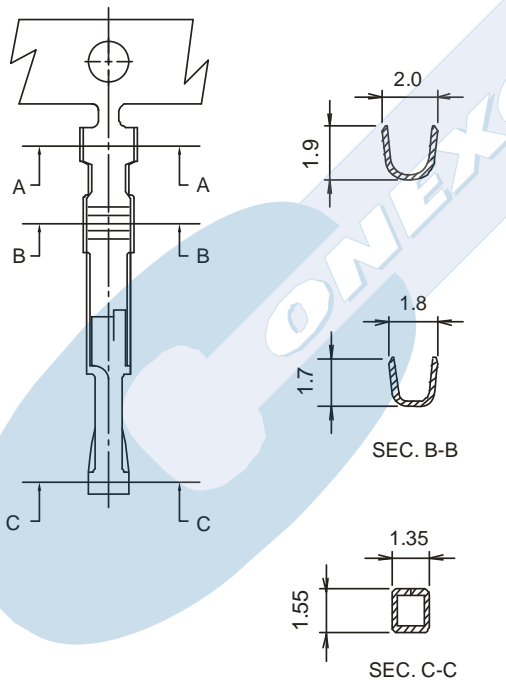

2870 - T- 00- E
1 2

1. Terminal Serie
2. (T) Contact Plating
 - T = 2. Tin plated
2. (E) Packing Options
 - E = 0. Chain
 - E = 1. Loose Piece

