

REV.	ECN NO OR DESCRIPTION	REVISED	DATE
A	PDR NO.:T090522-3B	Steve	2009.07.30

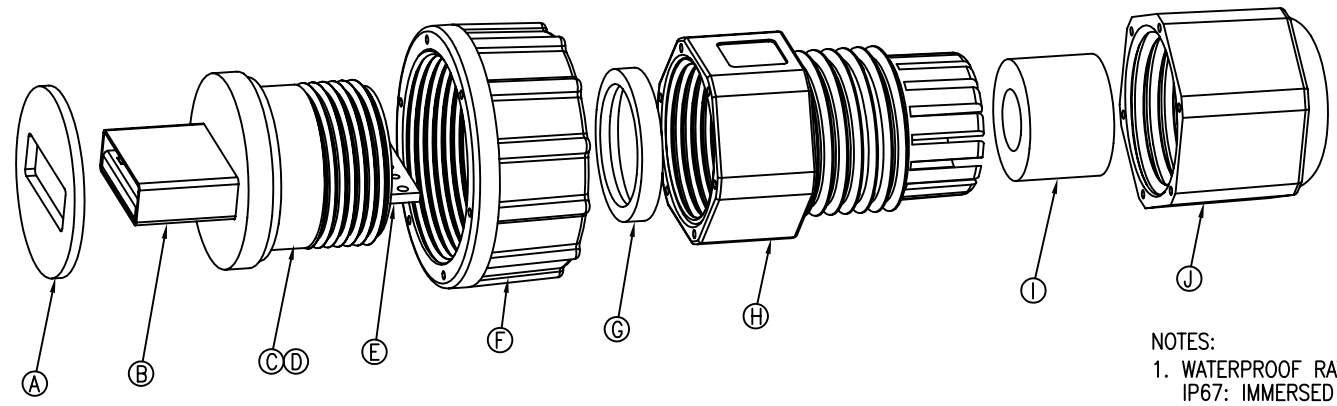

NOTES:

1. WATERPROOF RATE: IP67
IP67: IMMERSED IN 1M WATER FOR 30 MINUTES
2. ELECTRICAL CHARACTERISTICS:
1-1. RATING:30V 1A
1-2. CONTACT RESISTANCE: 30mΩ MAX.(INITIAL)
1-3. DIELECTRIC WITHSTANDING VOLTAGE: 500V AC FOR ONE MINUTE
1-4. INSULATION RESISTANCE: 100MΩ MIN. MEASURED BY 500 VDC
3. OTHER GENERAL SPEC. TO REFER "2UP2002 SERIES SPEC".
4. TO CONFORM TO HAZARDOUS SUBSTANCE FREE SPEC.
5. GREEN PRODUCT IDENTIFICATION LABEL ON PACKAGING: G.P. PASS

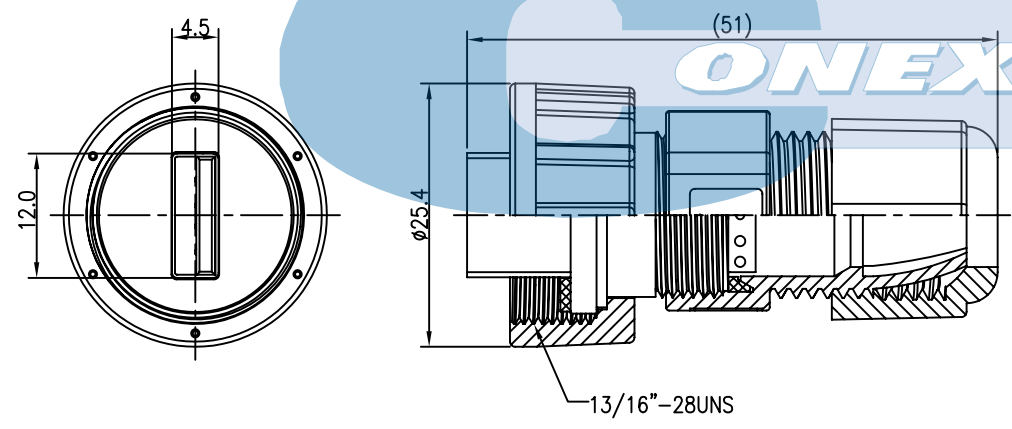

J	SEALING NUT	1	PPE	BLACK
I	SEAL	1	EPDM	BLACK
H	CLAMP RING	1	PPE	BLACK
G	GASKET	1	SILICONE	BLACK
F	SCREW NUT	1	PPE	BLACK
E	PCB	1	FR-4	GREEN
D	BODY	1	PPE	BLACK
C	LIGUID GLUE	1		BLACK
B	USB A PLUG	1		N/A
A	GASKET	1	EPDM	BLACK
NO	DESCRIPTION	QTY	MATERIAL	PLATING & COLOR

UNLESS OTHERWISE SPECIFIED TOLERANCES				
DECIMALS:	ANGLES:	TITLE	WATERPROOF USB2.0 A PLUG	
X :±0.5	X :±2°	DWN	Steve	Part Number: 3190-3041
X.X :±0.3	X.X :±1°	CHKD	Quan	SCALE 1:1 UNIT: mm
X.XX :±0.2		APVD	Max	SIZE: A3 SHEET:1 OF 1 REV: A
CUSTOMER COPY				