

S/ ROW SHROUDED R/ ANGLE HEADER SMT



3521 SERIES. 4.00 / 8.00 / 12.00 / 16.00 mm. (0.157 / 0.315 / 0.72 / 0.630 ”).

Features

- Available in 2 through 5 circuits
- Insulator: High temperatura plastic UL 94V-0
- Mates with 3520 series socket
- Terminal: Tin plated Brass
- Shrouded headers with Fixed Tabs
- Low profile with polarising device

Dimensional Information

Ordering and Dimensional Information

Circuit Size	Part Number	Dimensions			
		A	B	C	D
02	3521-2021E	4.0 (.157)	10.0 (.394)	6.5 (.256)	4.0 (.157)
02	3521-2022E	8.0 (.315)	14.0 (.551)	10.5 (.413)	8.0 (.315)
02	3521-2023E	12.0 (.472)	18.0 (.709)	14.5 (.571)	12.0 (.472)
02	3521-2024E	16.0 (.630)	22.0 (.866)	18.5 (.728)	16.0 (.630)
03	3521-2031E	4.0 (.157)	14.0 (.551)	10.5 (.413)	8.0 (.315)
03	3521-2032E	8.0 (.315)	22.0 (.866)	18.5 (.728)	16.0 (.630)
04	3521-2041E	4.0 (.157)	18.0 (.709)	14.5 (.571)	12.0 (.472)
05	3521-2051E	4.0 (.157)	22.0 (.866)	18.5 (.728)	16.0 (.630)

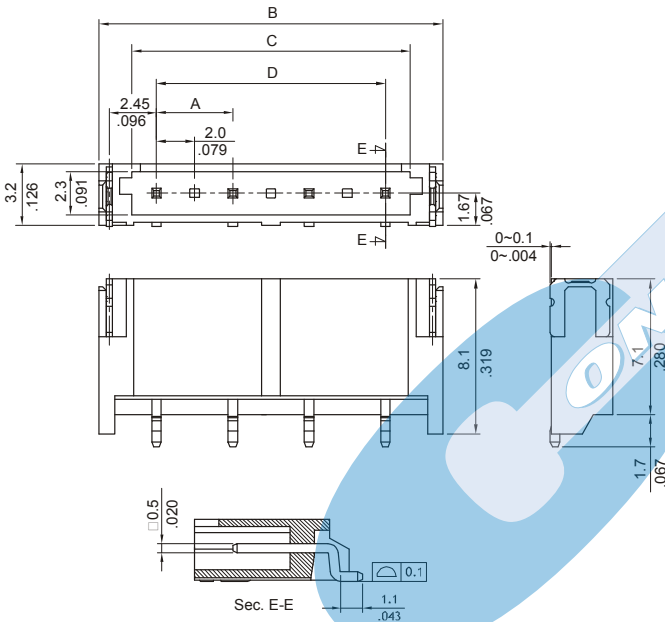

3521 - T- XX- P- E

1 2 3 4 5

1. Connector Series

2. (T) Plating Options

- T = 2. Tin Plated.

3. (XX) Circuit Size

- Available in 2, 3, 4 and 5 circuits

4. (P) Connector Pitch

- P = 1. (4.00 mm.)
- P = 2. (8.00 mm.)
- P = 3. (12.00 mm.)
- P = 4. (16.00 mm.)

5. (E) Packing Options

- E = 1. Tube+ Plastic Pad
- E = 2. Reel+ Plastic Pad

