

MALE CRIMP TERMINAL



5426 SERIES. 2.54 mm. (0.100 ") Pitch housing.

General Features

- Accommodates wire range AWG 28
- Use in housing 2.54 mm pitch 2427 series
- Male contact with locking lance
- Maximum insulation diameter 1.40 mm (0.055")

Materials

- Contact: Phosphor bronze
- Operating temperature -40°C to +85°C

Dimensional Information

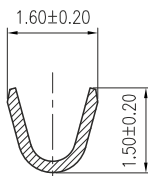
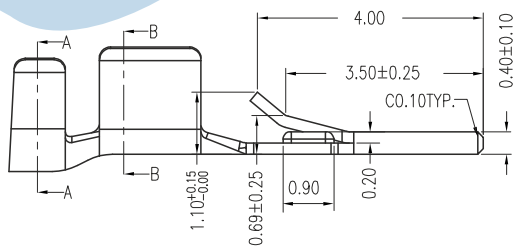
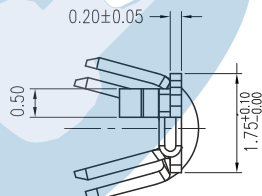
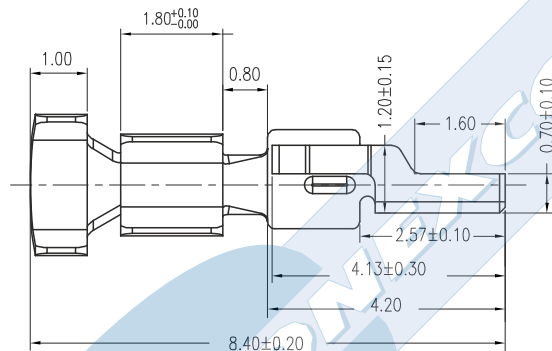

SEC. A-A

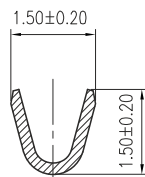

SEC. B-B

Electrical Features

- Current rating: < 1 A
- Contact resistance: < 20 mΩ

Mechanical Features

- Durability: 25 cycles
- Wire pull-out force: 1.00 Kgf 28 AWG



5426 - T- 00- E

1

2

1. Terminal Serie

2. (T) Contact Plating

- T = 2. Tin plated

2. (E) Packing Options

- E = 0. Chain
- E = 1. Loose Piece