

# CON. HEMBRA D/ FILA ENTRADA LATERAL



## SERIE 5455. Paso 2.54 mm. X 2.54 mm. (0.100" X 0.100"). Para soldar a PCB

### Características

- Disponible de 4 a 80 circuitos
- Conecta con machos de doble fila paso 2.54 mm.
- Material : P.B.T. UL 94V-0
- Su diseño robusto ofrece alta eficacia en el contacto
- Contacto de doble fleje en bronce fosforoso con diferentes acabados y baja fuerza de inserción
- Apilable de extremo a extremo

### Figuras y dimensiones

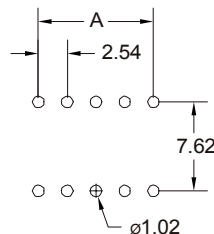
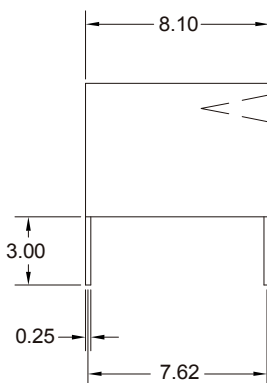
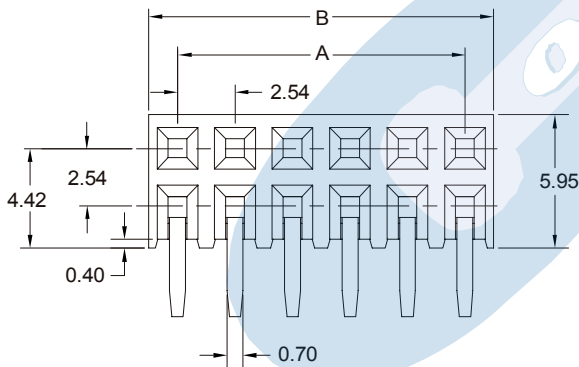
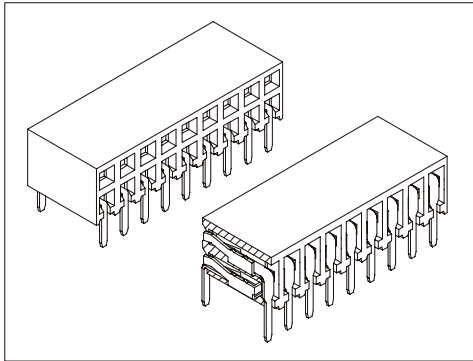

MECANIZADO RECOMENDADO

### Códigos y dimensiones

CIRCUITOS	CODIGO	DIMENSIONES	
		A	B
04	5455-T041	2,54(0,100)	5,08(0,300)
06	5455-T061	5,08(0,200)	7,62(0,300)
08	5455-T081	7,62(0,300)	10,16(0,400)
10	5455-T101	10,16(0,400)	12,70(0,500)
12	5455-T121	12,70(0,500)	15,24(0,600)
14	5455-T141	15,24(0,600)	17,78(0,700)
16	5455-T161	17,78(0,700)	20,32(0,800)
18	5455-T181	20,32(0,800)	22,86(0,900)
20	5455-T201	22,86(0,900)	25,40(1,000)
22	5455-T221	25,40(1,000)	27,94(1,100)
24	5455-T241	27,94(1,100)	30,48(1,200)
26	5455-T261	30,48(1,200)	33,02(1,300)
28	5455-T281	33,02(1,300)	35,56(1,400)
30	5455-T301	35,56(1,400)	38,10(1,500)
32	5455-T321	38,10(1,500)	40,64(1,600)
34	5455-T341	40,64(1,600)	43,18(1,700)
36	5455-T361	43,18(1,700)	45,72(1,800)
38	5455-T381	45,72(1,800)	48,26(1,900)
40	5455-T401	48,26(1,900)	50,80(2,000)
42	5455-T421	50,80(2,000)	53,34(2,100)
44	5455-T441	53,34(2,100)	55,88(2,200)
46	5455-T461	55,88(2,200)	58,42(2,300)
48	5455-T481	58,42(2,300)	60,96(2,400)
50	5455-T501	60,96(2,400)	63,50(2,500)
52	5455-T521	63,50(2,500)	66,04(2,600)
54	5455-T541	66,04(2,600)	68,58(2,700)
56	5455-T561	68,58(2,700)	71,12(2,800)
58	5455-T581	71,12(2,800)	73,66(2,900)
60	5455-T601	73,66(2,900)	76,20(3,000)
62	5455-T621	76,20(3,000)	78,74(3,100)
64	5455-T641	78,74(3,100)	81,28(3,200)
66	5455-T661	81,28(3,200)	83,82(3,300)
68	5455-T681	83,82(3,300)	86,36(3,400)
70	5455-T701	86,36(3,400)	88,90(3,500)
72	5455-T721	88,90(3,500)	91,44(3,600)
74	5455-T741	91,44(3,600)	93,98(3,700)
76	5455-T761	93,98(3,700)	96,52(3,800)
78	5455-T781	96,52(3,800)	99,06(3,900)
80	5455-T801	99,06(3,900)	101,60(4,000)

### T = Acabado de los contactos

- T = 2. Estañado.
- T = 3. Flash de Oro sobre 1.27 µ de Ni.  
ACABADO RECOMENDADO
- T = 5. 0.38 µ de Oro sobre 1.27 µ de Ni.
- T = 6. 0.75 µ de Oro sobre 1.27 µ de Ni.
- T = 13. Flash de Oro selectivo sobre 1.27 µ de Ni.
- T = 15. 0.38 µ Oro selec. sobre 1.27 µ de Ni.
- T = 16. 0.75 µ Oro selec. sobre 1.27 µ de Ni.