

# MICRO POWER RIGHT ANGLE HEADER SMT



## 5759 SERIES. 3.00mm(0.118"). For High Current / High Density

### Features

- Available in 2 through 24 circuits
- Insulator Material: Nylon 6T UL 94V-0, Colour: Black
- Contact Material: Brass
- Mates with 5740 series housing
- With metal board lock
- Different plating options are available
- Current Rating: 5 A maximum
- For other options consult the Sales Office

### Dimensional Information

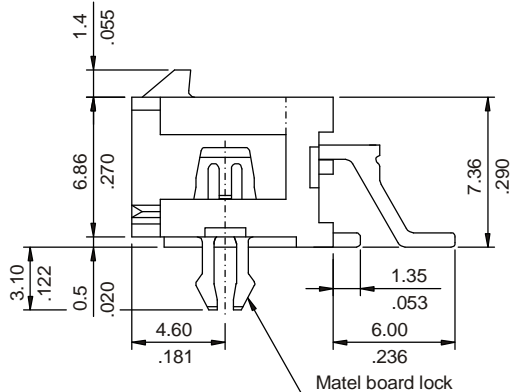
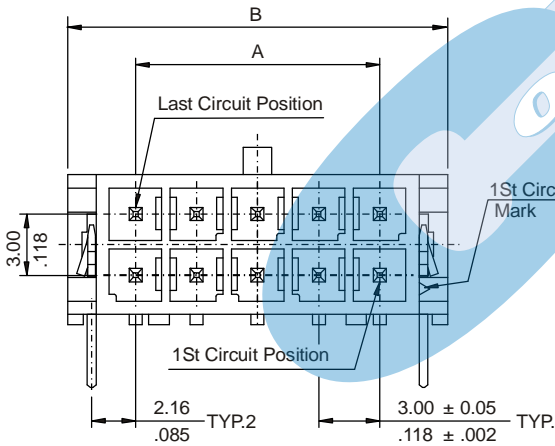
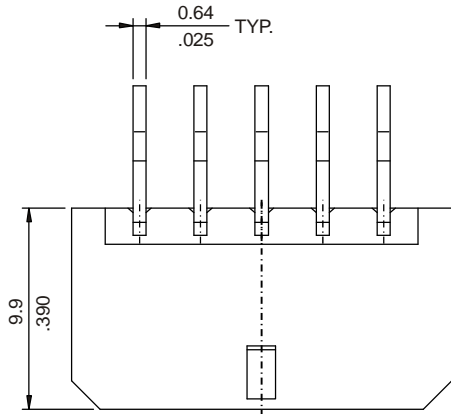

### Ordering and Dimensional Information

Circuit Size	Part Number	Dimensions	
		A	B
2	5759 - T021	-	6.70 (.264)
4	5759 - T041	3.00 (.118)	9.70 (.382)
6	5759 - T061	6.00 (.236)	12.70 (.500)
8	5759 - T081	9.00 (.354)	15.70 (.618)
10	5759 - T101	12.00 (.472)	18.70 (.657)
12	5759 - T121	15.00 (.591)	21.70 (.854)
14	5759 - T141	18.00 (.709)	24.70 (.972)
16	5759 - T161	21.00 (.827)	27.70 (1.091)
18	5759 - T181	24.00 (.945)	30.70 (1.209)
20	5759 - T201	27.00 (1.063)	33.70 (1.327)
22	5759 - T221	30.00 (1.181)	36.70 (1.445)
24	5759 - T241	33.00 (1.299)	39.70 (1.563)

### T = Contact Plating

- T = 2. Tin plated.

### Recommended Finish

- T = 13. Selective Gold flash over 50µ" nickel.
- T = 15. Selective 15µ" gold over 50µ" nickel
- T = 16. Selective 30µ" gold over 50µ" nickel

