

# TOP ENTRY SHIELDED PCB JACK FCC-68



## 7700 SERIES. Vertical PCB jack. With leds and filters.

### General Features

- Available in 8/8 circuits
- Standard telephone jack FCC-68
- 17.00 mm. height
- Accept standard plugs FCC-68 type
- Selective gold plating with different plating
- Bifurcated metallic foot print
- With or Without leds and LAN filter
- Different filter options

### Materials

- Insulator: Thermoplastic UL 94V-0
- Contact: 0.35 mm thickness phosphor bronze
- Shielded: 0.25 mm thickness brass
- Operating temperature. -25°C to +70°C
- RoHS compliant

### Dimensional Information



### Electrical Features

- Voltage rating: < 125V
- Current rating: < 1.50 A
- Contact resistance: < 20 mΩ
- Dielectric withstanding voltage: 300 V AC/minute
- Insulation resistance: >1000 MΩ

### Mechanical Features

- Durability: 1000 cycles

Part Number		LED Colour	
Position Leds A	Position Leds B	LED 1	LED 2
7700 – T8801F*	7700 – T8802F*	W/O Led	W/O Led
7700 – T8811F*	7700 – T8812F*	Green	Yellow
7700 – T8821F*	7700 – T8822F*	Yellow	Green
7700 – T8831F*	7700 – T8832F*	Green	Green
7700 – T8841F*	7700 – T8842F*	Yellow	Yellow

\*Replace F for the type of filter

### T = Contact Plating

- T = 4. 10μ" gold over 50μ" nickel
- T = 5. 15μ" gold over 50μ" nickel
- T = 6. 30μ" gold over 50μ" nickel
- T = 7. 50μ" gold over 50μ" nickel

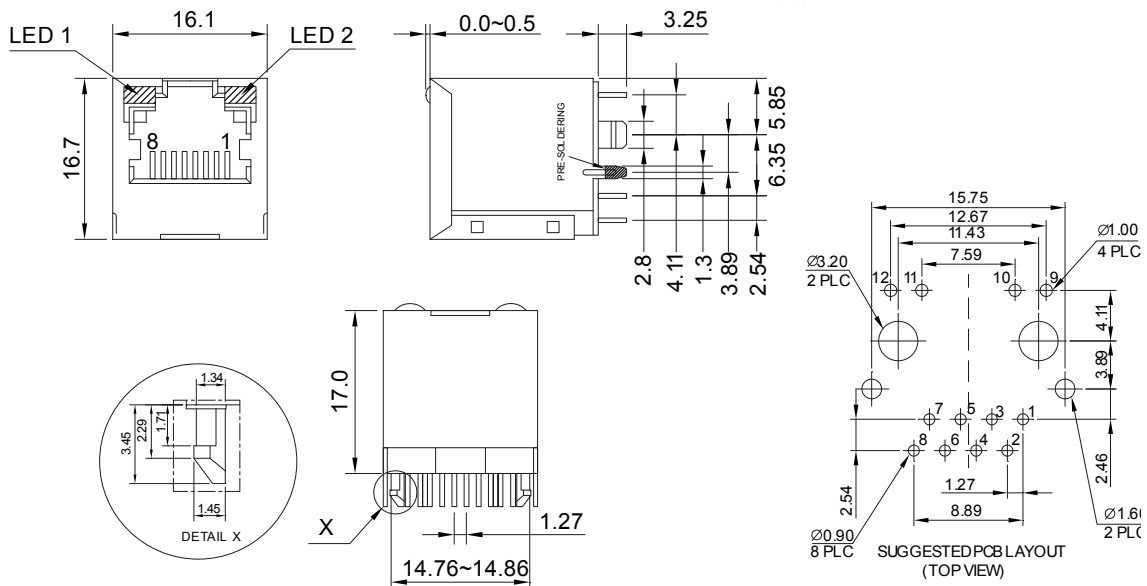
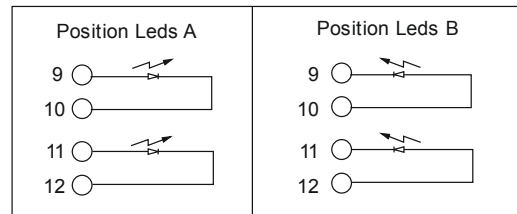

# SIDE ENTRY SHIELDED PCB JACK FCC-68



**7700 SERIES.** Vertical PCB jack. With leds and filters.

Filter Type:

