

SOLDER TYPE D-SUB RECEPTACLE



8001 SERIES. Solder Type D-Sub

Features

- Available in 9, 15, 19, 23, 25, 37 and 50 circuits
- Insulator Material: Glass filled polyester UL 94V-0
- Contact Material: Phosphor bronze
- Different plating options are available
- Shell: Steel, tin plated as standard
- Optional: #4-40 UNC hexagonal standoff or clinch nuts
- Other options: Hoods, mounting screw and accessories
- For other options consult the Sales Office

Dimensional Information

Ordering and Dimensional Information

Unit: $\frac{\text{mm.}}{\text{Inch.}}$

Circuit Size	Part Number	Dimensions			
		A	B	C	D
9	8001 - T09C	16.33 (0.643)	24.99 (0.984)	30.81 (1.213)	19.23 (0.757)
15	8001 - T15C	24.66 (0.971)	33.32 (1.312)	39.14 (1.541)	27.56 (1.085)
19	8001 - T19C	30.07 (1.184)	38.94 (1.533)	44.94 (1.769)	32.86 (1.294)
23	8001 - T23C	35.41 (1.394)	44.28 (1.743)	50.56 (1.991)	38.38 (1.511)
25	8001 - T25C	38.38 (1.511)	47.04 (1.852)	53.04 (2.088)	41.28 (1.625)
37	8001 - T37C	54.84 (2.159)	63.50 (2.500)	69.32 (2.729)	57.73 (2.273)
50	8001 - T50C	52.43 (2.064)	61.11 (2.406)	66.93 (2.635)	55.12 (2.170)

T = Contact Plating

- T = 3. Gold flash over 50 μ " nickel
- T = 4. 10 μ " gold over 50 μ " nickel
- T = 5. 15 μ " gold over 50 μ " nickel
- T = 6. 30 μ " gold over 50 μ " nickel

C = Hardware Options

- C = 1. Standard with 3.05mm (.012") dia. mount hole
- C = 2. Version T2
- C = 3. Version T4
- C = 4. Version D2

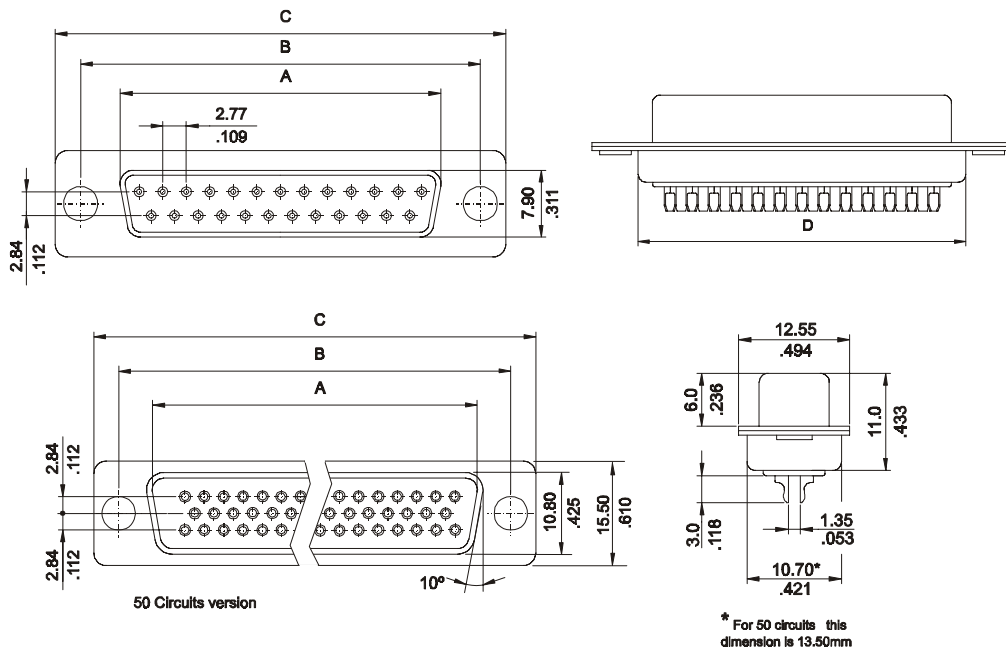

C = Hardware Options

